

REV.	DATE	ECN#	BY
-	24APR2015	65695	RC

REVISION TABLE	
----------------	--

DESCRIPTION	WIRE DIAGRAM, 3 PHASE, SCC10 - EAGLE		
FILENAME	145220652	REV	-
DRAWN BY	ET	APP'D BY	REF
DATE	15APR15	SHEET	1 of 1
SIZE	B	SCALE	N.T.S.



SWITCH NO.	CONTACT	ACTUATOR POSITION			FUNCTION
		FULL RETRACT	INTERMEDIATE POSITION	FULL EXTEND	
1	A	—	—	—	FULL EXTEND POSITIO
	B	—	—	—	FULL RETRACT POSITIO
2	A	—	—	—	AUX (OPTIONAL)
	B	—	—	—	AUX (OPTIONAL)
3	A	—	—	—	AUX (OPTIONAL)
	B	—	—	—	AUX (OPTIONAL)
4	A	—	—	—	AUX (OPTIONAL)
	B	—	—	—	AUX (OPTIONAL)

SWITCH POSITION SHOWN WITH ACTUATOR IN FULLY EXTEND POSITION  
 ——— CLOSED SWITCH CONTACT  
 - - - - - OPEN SWITCH CONTACT

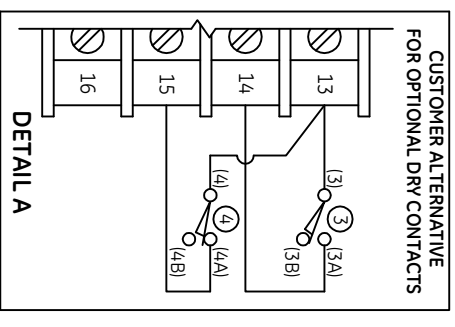

\* ALARM OUTPUT WILL BE OPEN WHEN POWER OFF, IF IN FAULT OR WHEN DISPLAY IS IN MENU MODE.

NOTES:

- LIMIT SWITCH DATA:  
QUICK CONNECT TERMINALS MICROSWITCH V3L-3005-D8 OR EQUIVALENT. RATING: 15 AMP AND 1/2 HP, 125 OR 250 VAC, 1/2 AMP, 125 VDC; 1/4 AMP, 250 VDC; 5 AMP, 120 VAC "L" (LAMP LOAD).
- OPTIONAL(OPT.) COMPONENTS SHOWN ARE AUX DRY CONTACTS.
- WARNING: PROTECTIVE EARTH GROUNDING, GROUNDING LUG MUST BE WIRED TO SUITABLE GROUNDING SYSTEMS WITH MIN. #10 AWG WIRE.
- HEATER MUST BE WIRED TO CONTINUOUS POWER.
- IMPORT/EXPORT HARMONIZATION CODE HARDCOPY, 4906000000
- HI-POT TEST:  
PERFORM HI-POT TEST PER UL61010 F.3. (REFER TO IOM.) TEST AT TERMINALS T1, T2, & T3 PER MOTOR VOLTAGE. UNPLUG THE PLUG CONNECTOR FROM TB1. TEST AT TERMINALS 1, THROUGH 9 PER CONTACTOR COIL VOLTAGE (IF CONNECTED) OR TO 240 VAC IF NO CONTACTOR IS CONNECTED. TEST AT TERMINALS 13, 14, & 15 PER 240VAC. DO NOT PERFORM HI-POT TEST ON CONTROL CARD CIRCUITS OR TB2. RECONNECT PLUG CONNECTOR TO TB1.
- REFER TO UNIT NAME PLATE.
- EXTERNAL CONTROL DEVICES 4.5 AMPS MAX
- DISCONNECT SWITCH: (NOT SUPPLIED WITH ACTUATORS) MUST BE SUITABLY LOCATED, EASILY REACHED AND MARKED AS THE DISCONNECTED DEVICE FOR THE EQUIPMENT.

LEGEND

- ①③ - EXTEND POSITION LIMIT SWITCH
- ②④ - RETRACT POSITION LIMIT SWITCH
- - WIRING CONNECTION
- - SWITCH CONNECTION
- - SWITCH CONTACT
- - - - - CUSTOMER WIRING