

# Andco\* Actuators

Precise positioning and reliable automation for controlled motion





## Table of Contents

Overview .....	3
Eagle Linear Actuator .....	4
7000 Series Linear Actuator .....	6
Standard Options	
Mounting: Clevis, Trunnion, Flange .....	15
Manual Override.....	15
Extension Rod Cover .....	16
Adjustable Gear Driven Position Limit Switch .....	16
Gear Driven Potentiometers.....	16
Electric Motor Brake .....	17
Single Phase Electronic (Dynamic) Motor Braking .....	17
Three Phase Motor Control .....	17
Positran® Transmitter .....	17
Controls	
EASC - Electric Actuator Smart Control.....	18
Profibus DP® .....	20
DeviceNet™ .....	21
Modbus® .....	22



GE's Andco\* electric linear and rotary actuators offer a superior technology choice when reliable, precise, controlled motion is required. Whether moving industrial doors, providing accurate positioning feedback for antennas, or modulating and controlling louver dampers, customers can rely on Andco actuator solutions.

The Andco actuator portfolio includes weatherproof and dustproof options, offering customers durability and performance in severe industrial environments, including hot and cold temperature extremes. Andco actuators are a superior solution for a range of functions including positioning, lifting/lowering, pushing/pulling, and opening/closing.

Andco actuator technology offers low maintenance packages with internal adjustable limit switches for on/off control and light indication, internal torque switch for overload protection, optional internal position/process controls for positioning, motor braking and motor control. Our actuator solutions deliver ease of installation, maintain constant output force and velocity, and consume power only during movement.



# Andco\* Eagle\* Actuators

GE's Andco Eagle Linear Actuator is a completely self-contained electro-mechanical device. Its compact design is equivalent in size to hydraulic or pneumatic cylinders. Designed and fabricated for easy installation and dependable long-life operation, these actuators are driven by a high starting torque motor with thermal overload protection, non-rotating extension rod, non-backdriving acme screw and all metal gearing.

## Features

- Non-rotating drive rod
- Non-backdriving
- All metal gearing
- Compact with electro-mechanical repeatability
- Simple to mount; easy to wire
- Comparable cost to pneumatic or hydraulic systems
- Equivalent in size to hydraulic or pneumatic cylinders
- Operating range -40°F to +150°F

## Standard Equipment

- Thermal switch in motor winding
- Two independently adjustable, gear driven position limit switches with all metal gearing
- Nickel-plated drive rod
- Clevis and pin on drive rod end
- Type 4 Weatherproof and Dust-Ignition proof enclosure (Class II, Division 1, Groups E, F and G)
- Anti-friction bearings on all drive components
- All metal gearing
- Cast aluminum construction
- Clevis mount on the motor end
- Permanently lubricated for maintenance-free operation
- Heavy-duty industrial motor; 115 VAC, 60 Hz, single phase, TENV, permanent split capacitor, high starting torque, low inertia



### Temperature Range

Ambient -40°F to +150°F  
-40°C to +65°C

### Motor Data

120 VAC, 1 Phase, 50/60 Hz, 2.6/3.0A<sup>1</sup>  
230 VAC, 1 Phase, 50/60 Hz, 1.7A<sup>1</sup>  
210-240 VAC, 3 Phase, 50/60 Hz, 0.6A<sup>1</sup>  
380-480 VAC, 3 Phase, 50/60 Hz, 0.4A<sup>1</sup>  
575 VAC, 3 Phase, 60 Hz, 0.2A<sup>1</sup>

Class B Insulation

NEMA "D" design

### Approvals

CSA available on select models

<sup>1</sup>Full load current (Amps).

## Optional Equipment

- 230 VAC, 460 VAC and 575 VAC, 60 Hz, 3 phase motor
- Potentiometer (all metal gear driven)
- Integral position process control board for modulating applications
- 4-20mA position transmitter
- Adjustable trunnion mount and trunnion brackets
- Adjustable face/flange mount
- Manual override
- Modbus



# Dimensions

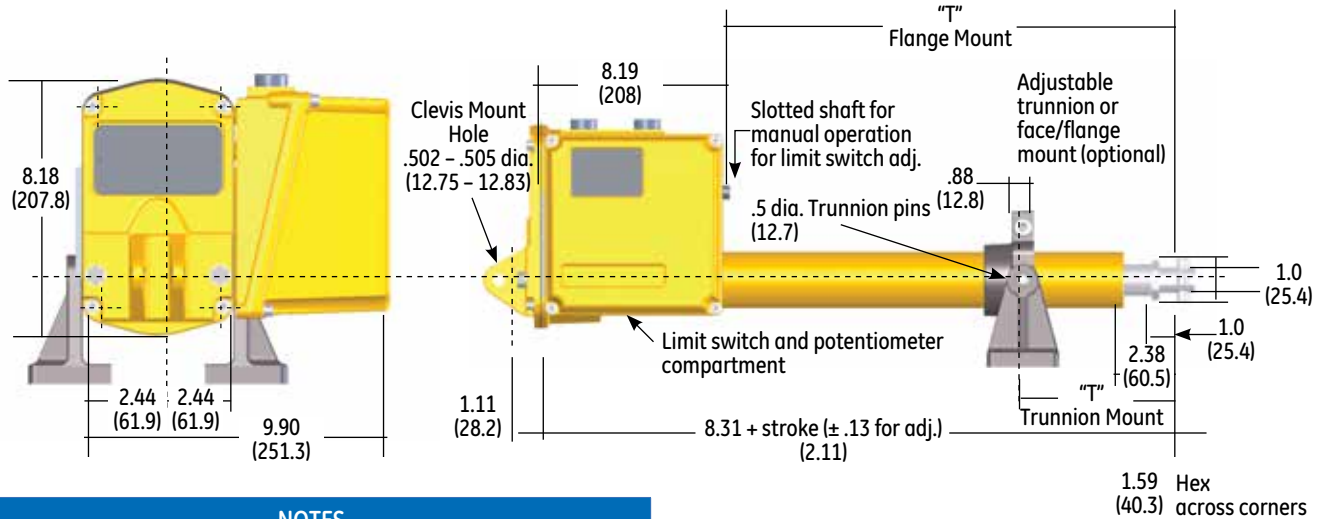
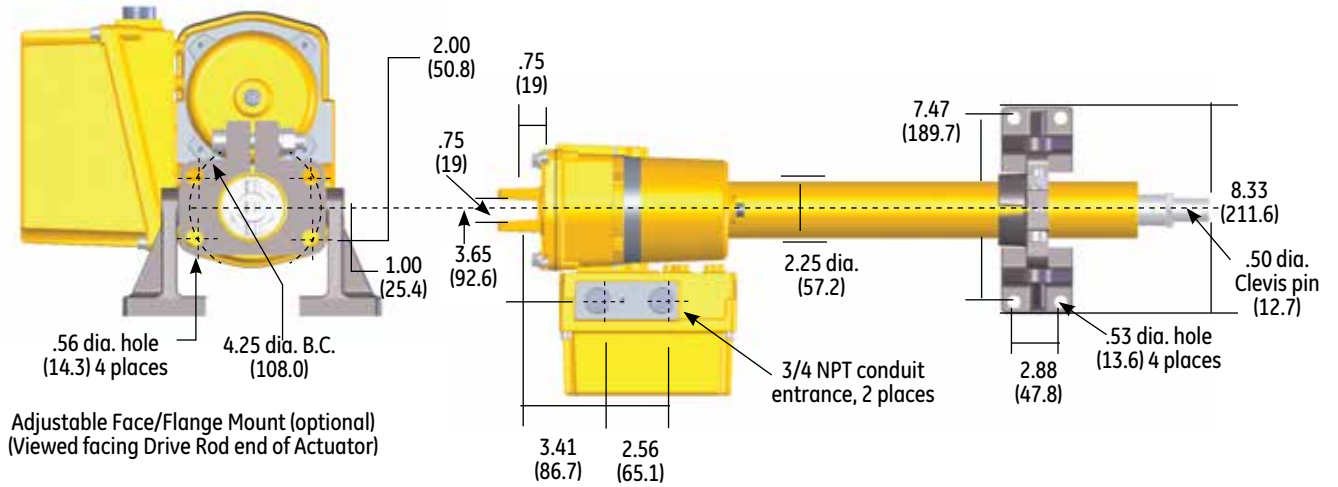

- NOTES**
1. Unbracketed dimensions are in inches.
  2. Bracketed dimensions are in millimeters.
  3. Dimensions shown with actuator fully retracted.
  4. Dimensions are for reference only. Please contact GE for engineering drawings.

## Eagle Electrical Cylinder Performance

3100 Series				
Velocity (in/sec)	Breakway Force (lbs)	Running Force (lbs at 25% duty)	Weight Range (lbs)	Stroke (in)
0.2	2000	1000	35-75	6, 12
0.4	1500	750		8, 24
0.8	750	340		30, 36
2.0	500	200		

## Adjustable Trunnion or Face/Flange

"T" Adjustable Dimension		
Stroke	Inches	Millimeters
6	2.38 - 2.88	(60.45 - 73.15)
12	2.38 - 8.00	(60.45 - 203.20)
18	2.38 - 14.00	(60.45 - 355.60)
24	5.38 - 20.00	(136.65 - 508.00)
30	11.38 - 26.00	(289.05 - 660.40)
36	17.38 - 32.00	(441.45 - 812.80)

# Andco\* 7000 Series\* Actuators

The Andco 7000 Series linear actuator is a completely self-contained, electro-mechanical device. Designed and fabricated for dependable, long-life operation, these actuators are used for positioning, automation of material handling, or flow control equipment.

7000 Series actuators are driven by a high starting torque, low inertia motor connected to a drive screw through a set of gears. When the motor rotates the drive screw, the mating nut and attached extension rod move axially.

Upon completion of stroke, the gear driven position limit switch interrupts power to the motor. If movement of the extension rod is prevented in either direction at any point in actuator travel due to an external mechanical overload, a thrust switch will interrupt power to the motor.

1. High strength ground and plated extension rod
2. Front end cap with bearing support, rod wiper and grease seal
3. Four tie-rod construction with guided drive nut
4. Thrust limit disc springs and spring limit sleeve to prevent total spring deflection
5. Anti-friction bearings
6. High strength alloy steel cut gears
7. Gear driven potentiometer or encoder drives available
8. Heavy duty motor, TENV, NEMA D design, high starting torque, low inertia motor provides high breakaway forces and good positioning characteristics; Class F insulation is standard
9. Versatile mounting, clevis (7100 only), trunnion or face/flange

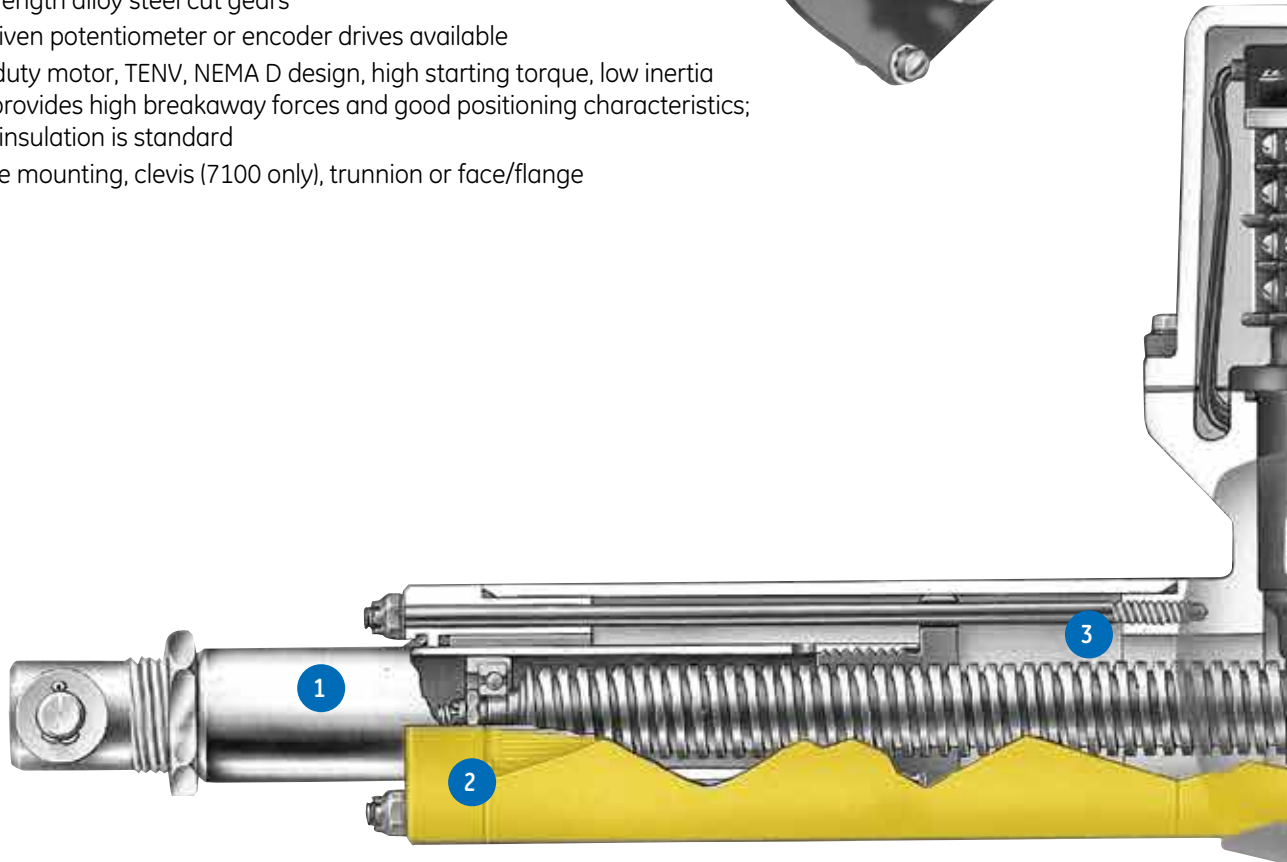
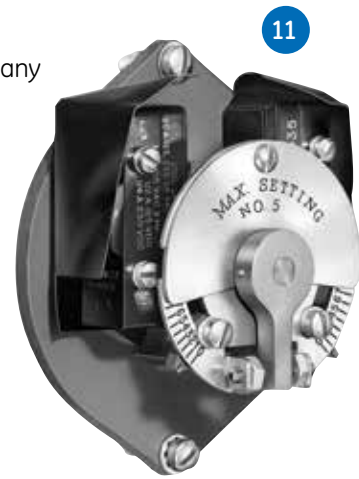

10. A two position gear driven position limit switch for end-of-travel actuator shutoff and a set of contacts for light indication are included as standard. Each position is independently adjustable and can be set anywhere within the full actuator travel. The heavy duty rotary drum, double break switch with wiping contacts feature a patented mechanism that ensures internal gear engagement after adjustment.
11. An adjustable thrust switch for each direction of travel is provided as standard. The switch assembly will automatically shut off the actuator if the set force is exceeded. The switch protects driven equipment from damage due to excessive forces and can also be used as a mechanism for positive seating.

### Other Features

- Weatherproof or Dust-Ignition Proof Enclosure (Class II, Divisions 1, Groups E, F, and G)
- Plated external hardware
- Permanently lubricated
- Non-backdriving acme screw
- Efficient ball screws with motor brake
- Electrical components are prewired and terminated inside the actuator

Temperature Range	
Ambient	-30°F to +120°F -34°C to +48°C
Motor Data	
	115 VAC, 1 Phase
	230 VAC, 3 Phase
	460 VAC, 3 Phase
	575 VAC, 3 Phase
	Class F Insulation NEMA "D" design
Approvals	
	CSA available on select models <sup>1</sup>

<sup>1</sup> Not available on 7400 or 7500 models.

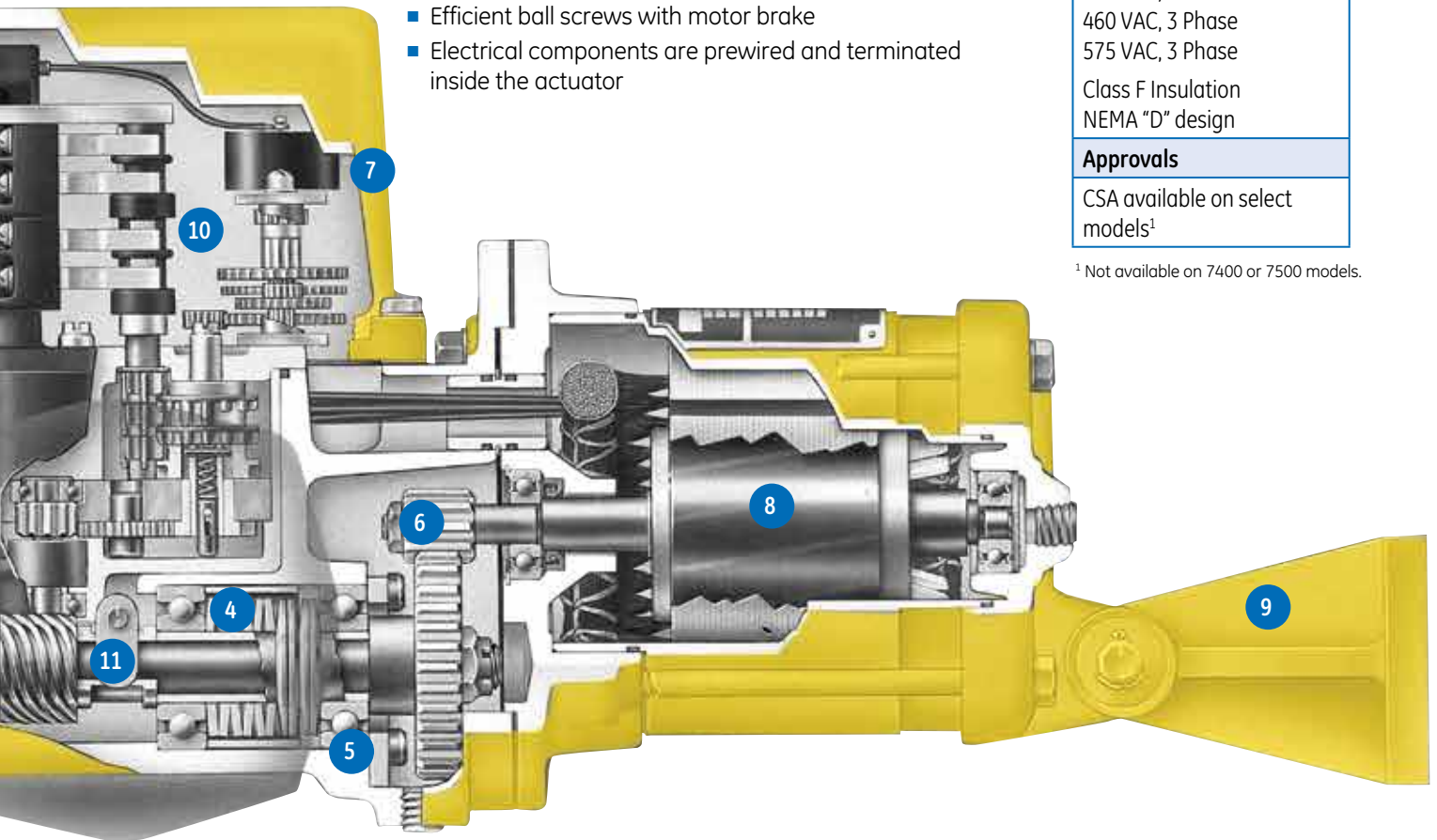

# Andco\* 7000 Series\* Actuators

## 7000 Series Acme Screw Linear Actuators

Model	Velocity (in/sec)	Breakaway Thrust Rating (lbs)	Running Thrust Rating (lbs)			Stroke Range (ins)	Approximate Weight Range (lbs)
			5% Duty	10% Duty	25% Duty		
<b>7102S</b> (1-Phase)	0.8	975	450	330	130	6-24	50-80
	1.1	750	325	240	95		
	2.0	410	175	135	50		
	2.8	290	125	90	35		
<b>7105T</b>	1.1	2,100	650	240	95	6-24	45-80
	2.0	1,225	350	135	50		
	2.8	875	250	90	35		
<b>7202S</b> (1-Phase)	1.1	750	330	330	260	6-36	55-100
	1.5	460	240	240	180		
	2.8	300	130	130	100		
	4.0	215	90	90	70		
<b>7205T</b>	1.5	1,700	480	460	-	6-36	50-100
	2.8	900	260	255	-		
	4.0	650	185	180	-		
<b>7210T</b>	1.5	2,100	1,000	-	-	6-36	50-100
	2.8	1,815	510	-	-		
	4.0	1,300	370	-	-		
<b>7310T</b>	1.4	2,530	1,100	1,050	525	6-60	85-185
	2.1	1,750	700	700	350		
	3.2	1,130	455	455	225		
<b>7317T</b>	2.1	4,220	1,300	1,300	-	6-60	100-200
	3.2	2,750	850	520	-		
<b>7324T</b>	2.0	5,900	1,750	-	-	6-60	100-200
	3.2	3,800	1,250	-	-		
<b>74-7330T</b>	2.8	5,200	2,850	-	-	6-60	120-240
	3.6	4,000	2,200	-	-		

## 7000 Series Acme Screw Linear Actuators with Gearbox Assembly

Model	Velocity (in/sec)	Breakaway Thrust Rating (lbs)	Running Thrust Rating (lbs)			Stroke Range (ins)	Approximate Weight Range (lbs)
			5% Duty	10% Duty	25% Duty		
<b>7202S</b> (1-Phase)	0.2	2,100	1,100	1,100	1,100	6-36	65-110
<b>7205T</b>	0.5	2,100	1,100	1,100	1,100	6-36	65-110
<b>7302S</b> (1-Phase)	0.2	4,560	1,845	1,845	1,845	6-60	95-190
	0.4	2,130	920	920	920		
	0.7	1,130	490	490	490		
<b>7305T</b>	0.4	6,200	1,795	1,795	1,795	6-48	90-160
<b>7324T</b>	1.1	7,000	3,075	-	-	6-48	115-205
<b>74-7330T</b>	1.5	7,000	5,100	-	-	6-60	130-250



# Andco\* 7000 Series\* Actuators

## 7000 Series Ball Screw Linear Actuators

Model	Velocity (in/sec)	Breakaway Thrust Rating (lbs)	Running Thrust Rating (lbs)			Stroke Range (ins)	Approximate Weight Range (lbs)
			5% Duty	20% Duty	25% Duty		
<b>7302S</b> (1-Phase)	1.4	1,990	670	670	670	6-48	110-190
	2.1	1,370	460	460	460		
	3.2	890	300	300	300		
	4.2	690	230	230	230		
	6.4	450	150	150	150		
	12.2	240	80	80	80		
<b>7310T</b>	1.4	7,000	2,680	2,680	2,680	6-48	110-190
	2.1	5,780	1,850	1,850	1,850		
	4.2	2,900	920	920	920		
	6.4	1,875	600	600	600		
	12.2	940	320	320	320		
<b>7317T</b>	2.1	7,000	3,230	2,700	2,560	6-48	110-210
	4.2	7,000	1,610	1,610	1,530		
	6.4	4,550	1,050	1,050	995		
	12.2	2,400	550	550	525		
<b>7324T</b>	4.2	7,000	3,400	2,300	-	6-48	120-260
	6.4	6,600	2,200	1,500	-		
	12.2	3,400	1,150	790	-		

## 7400 Series Ball Screw Linear Actuators

Model	Velocity (in/sec)	Breakaway Thrust Rating (lbs)	Running Thrust Rating (lbs)			Stroke Range (ins)	Approximate Weight Range (lbs)
			5% Duty	10% Duty	25% Duty		
<b>7430T</b>	4.2	12,000	5,100	4,900	4,700	12-60	135-350
<b>7450T</b>	5.5	16,000	7,000	6,100	4,900	12-60	125-375

## 7500 Series Ball Screw Linear Actuators

Model	Velocity (in/sec)	Breakaway Thrust Rating (lbs)	Running Thrust Rating (lbs)			Stroke Range (ins)	Approximate Weight Range (lbs)
			5% Duty	10% Duty	25% Duty		
<b>7530T</b>	2.0	24,000	12,000	11,000	10,000	12-60	275-575
<b>7550T</b>	2.0	42,000	20,000	16,000	12,500	12-60	275-625

### NOTES

1. The suffix S in the model number indicates a 115 VAC, 60 Hz single phase motor. 220 VAC, 60 Hz single phase is optional.
2. The suffix T in the model number indicates a 230 or 460 VAC, 60 Hz three phase. 380 VAC, 50 Hz and 575 VAC, 60 Hz are optional.
3. Strokes are available in 6 inch increments up to 36 inches and 12 inch increments up to 60 inches.
4. All stroke lengths can be adjusted downward with the position limit switch.
5. The information contained herein is in effect at the time of printing and the company reserves the right to make changes.

# Andco\* 7000 Series\* Actuators

## 7000 Series Acme Screw Linear Actuators

Model	6" Stroke		12" Stroke		18" Stroke		24" Stroke		30" Stroke		36" Stroke		48" Stroke		60" Stroke	
	A	B	A	B	A	B	A	B	A	B	A	B	A	B	A	B
7102S	26.32	18.14	32.32	24.14	38.32	30.14	44.32	36.14	-	-	-	-	-	-	-	-
7105T	25.32	18.14	31.32	24.14	37.32	30.14	43.32	36.14	-	-	-	-	-	-	-	-
7202S	26.17	18.58	32.17	24.58	38.17	30.58	44.17	36.58	50.17	42.58	56.17	48.58	-	-	-	-
7205T	25.17	18.58	31.17	24.58	37.17	30.58	43.17	36.58	49.17	42.58	55.17	48.58	-	-	-	-
7210T	26.17	18.58	32.17	24.58	38.17	30.58	44.17	36.58	50.17	42.58	56.17	48.58	-	-	-	-
7310T	32.45	24.88	38.45	30.88	44.45	36.88	50.45	42.88	56.45	48.88	62.45	54.88	74.45	66.88	86.45	78.88
7317T	32.88	24.88	38.88	30.88	44.88	36.88	50.88	42.88	56.88	48.88	62.88	54.88	74.88	66.88	86.88	78.88
7324T	33.82	24.88	39.82	30.88	45.82	36.88	51.82	42.88	57.82	48.88	63.82	54.88	75.82	66.88	87.82	78.88
74-7330T	39.30	29.36	45.30	35.36	51.30	41.36	57.30	47.36	63.30	53.36	69.30	59.36	81.30	71.36	93.30	83.36

Model	C	D	E	F	G	H	J	K	L	M1	M2	N	P	R	S
7102S	2.50	.375	.38	2.53	1.00	.38	1.63	0.94	2.32	8.18	6.00	1.60	2.65	3.60	4.68
7105T										7.18					
7202S	2.75	.500	.50	2.40	1.00	.50	1.63	0.94	2.32	7.59	6.00	1.60	2.65	3.60	4.68
7205T										6.59					
7210T										7.59					
7310T	3.88	.750	.63	4.32	1.13	.75	2.25	3.29	4.72	7.57	6.00	2.00	2.82	4.19	5.18
7317T										8.00					
7324T										8.94					
74-7330T	4.38	1.25	1.26	6.13	2.00	1.25	3.25	3.29	4.72	9.94	6.86	2.00	2.82	4.19	5.18

## 7000 Series Screw Linear Actuators with Gearbox Assembly

Model	6" Stroke		12" Stroke		18" Stroke		24" Stroke		30" Stroke		36" Stroke		48" Stroke		60" Stroke	
	A	B	A	B	A	B	A	B	A	B	A	B	A	B	A	B
7102S	30.88	18.58	36.88	24.58	42.88	30.58	48.88	36.58	54.88	42.58	60.88	48.58	-	-	-	-
7205T	29.88	18.58	35.88	24.58	41.88	30.58	47.88	36.58	53.88	42.58	59.88	48.58	-	-	-	-
7302S	37.63	24.88	43.63	30.88	49.63	36.88	55.63	42.88	61.63	48.88	67.63	54.88	79.63	66.88	91.63	78.88
7305T	36.63	24.88	42.63	30.88	48.63	36.88	54.63	42.88	60.63	48.88	66.63	54.88	78.63	66.88	90.63	78.88
74-7330T	53.20	29.36	59.20	35.36	65.20	41.36	71.20	47.36	77.20	53.36	83.20	59.36	95.20	71.36	107.20	83.36

# Andco\* 7000 Series\* Actuators

## 7000 Series Acme Screw Linear Actuators

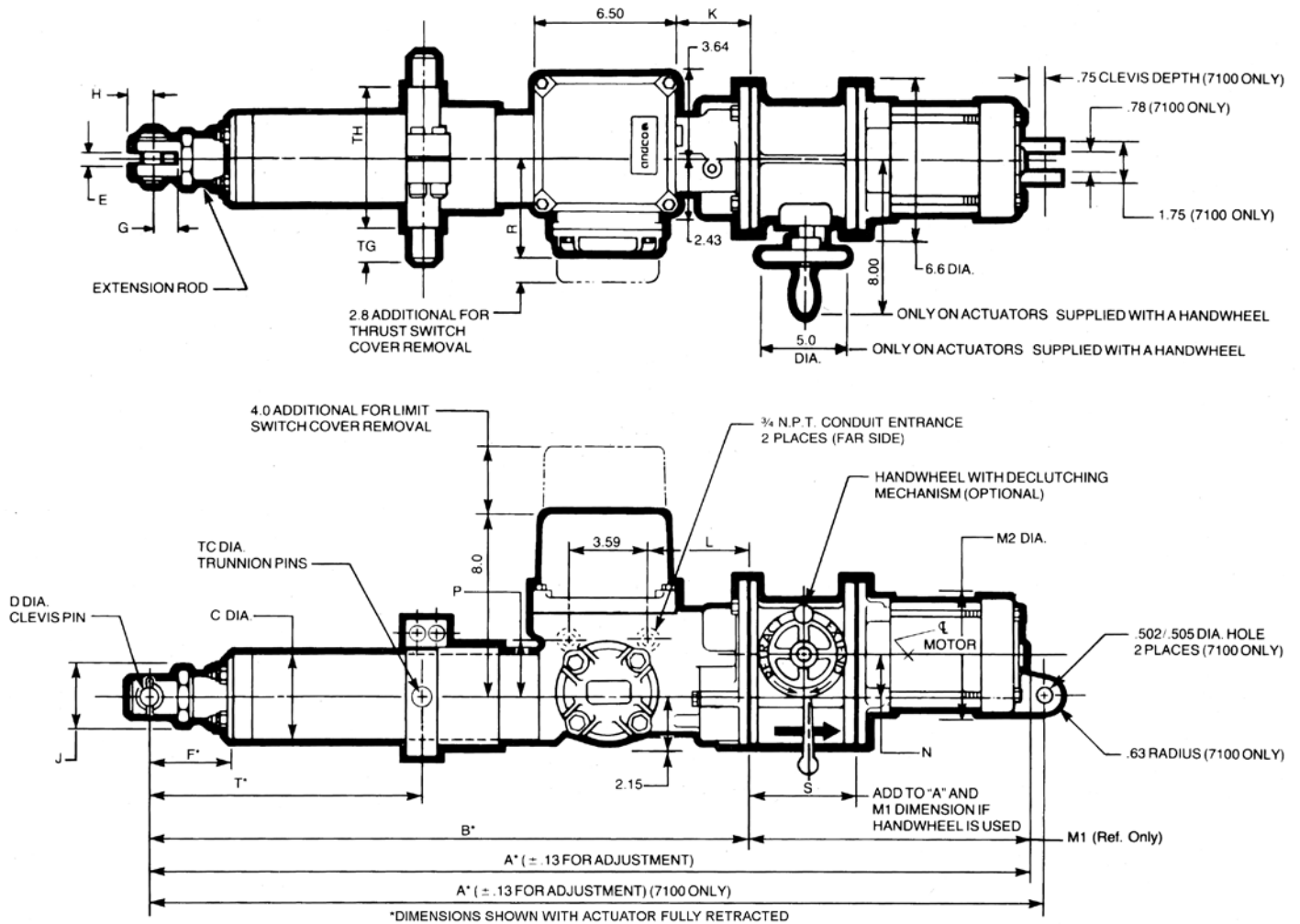

Model	C	D	E	F	G	H	J	K	L	M1	M2	N	P	R	S
7102S	2.75	.50	.50	2.50	1.00	.50	1.63	.94	2.32	12.30	6.00	1.60	2.65	3.60	4.68
7205T										11.30					
7302S	3.88	.75	.63	4.32	1.13	.75	2.25	3.29	4.72	12.75	6.00	2.00	2.82	4.19	5.18
7305T										11.75					
74-7330T	4.38	1.25	1.26	6.13	2.00	1.25	3.25	3.29	4.72			2.00	2.82	4.19	5.50

Series	N1	N2	N3
7100	1" - 20UN	1.00	1.187
7200	1-1/4" - 20UN	1.12	1.433
7300	1-5/8" - 16UN	1.18	1.860
74-7300	1-1/8" - 16UN	2.06	2.350

### NOTES

For trunnion, clevis, and face flange mount dimensions see pages 14 and 15. Dimensions are for reference only. Contact GE for engineering drawings.

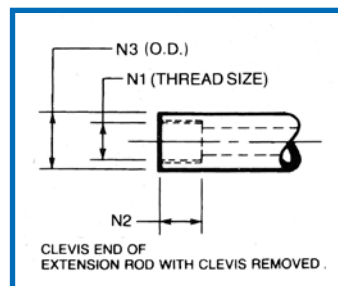

# Andco\* 7000 Series\* Actuators

## 7000 Series Ball Screw Linear Actuators

Model	6" Stroke		12" Stroke		18" Stroke		24" Stroke		30" Stroke		36" Stroke		48" Stroke		60" Stroke	
	A	B	A	B	A	B	A	B	A	B	A	B	A	B	A	B
7302S	40.50	27.70	46.50	33.70	52.50	39.70	58.50	45.70	64.50	51.70	70.50	57.70	82.50	69.70	-	-
7301T	40.50	27.70	46.50	33.70	52.50	39.70	58.50	45.70	64.50	51.70	70.50	57.70	82.50	69.70	-	-
7317T	40.83	27.70	46.83	33.70	52.83	39.70	58.83	45.70	64.83	51.70	70.83	57.70	82.83	69.70	-	-
7324T	41.70	27.70	47.70	33.70	53.70	39.70	59.70	45.70	65.70	51.70	71.70	57.70	83.70	69.70	-	-
7430T	-	-	65.10	50.10	71.10	56.10	77.10	62.10	-	-	89.10	74.10	101.10	86.10	113.10	98.10
7450T	-	-	68.50	50.10	74.50	56.10	80.50	62.10	-	-	92.50	74.10	104.50	86.10	116.50	98.10
7530T	-	-	82.40	58.60	88.40	64.60	94.40	70.60	-	-	106.40	74.10	118.40	86.10	130.40	98.10
7550T	-	-	82.40	58.60	87.80	64.60	93.80	70.60	-	-	105.80	74.10	117.80	86.10	129.80	98.10

Model	C	D	E	F	G	H	J	K	L	M1	N	P	R	TC	TG	TH
7302S										12.80						
7310T										12.80						
7317T	3.88	0.750	0.63	4.00	1.13	0.75	2.25	3.29	4.72	13.13	2.00	2.82	4.19	0.875	1.19	6.50
7324T										14.00						
7430T										15.00						
7450T	4.38	1.250	1.26	6.13	2.00	1.25	3.25	3.29	4.72	18.40	2.00	2.82	4.19	1.000	1.50	7.50
7530T										23.80						
7550T	6.50	1.500	1.54	5.75	2.38	1.75	4.56	3.29	4.72	23.20	2.00	2.82	4.19	1.750	2.50	10.00

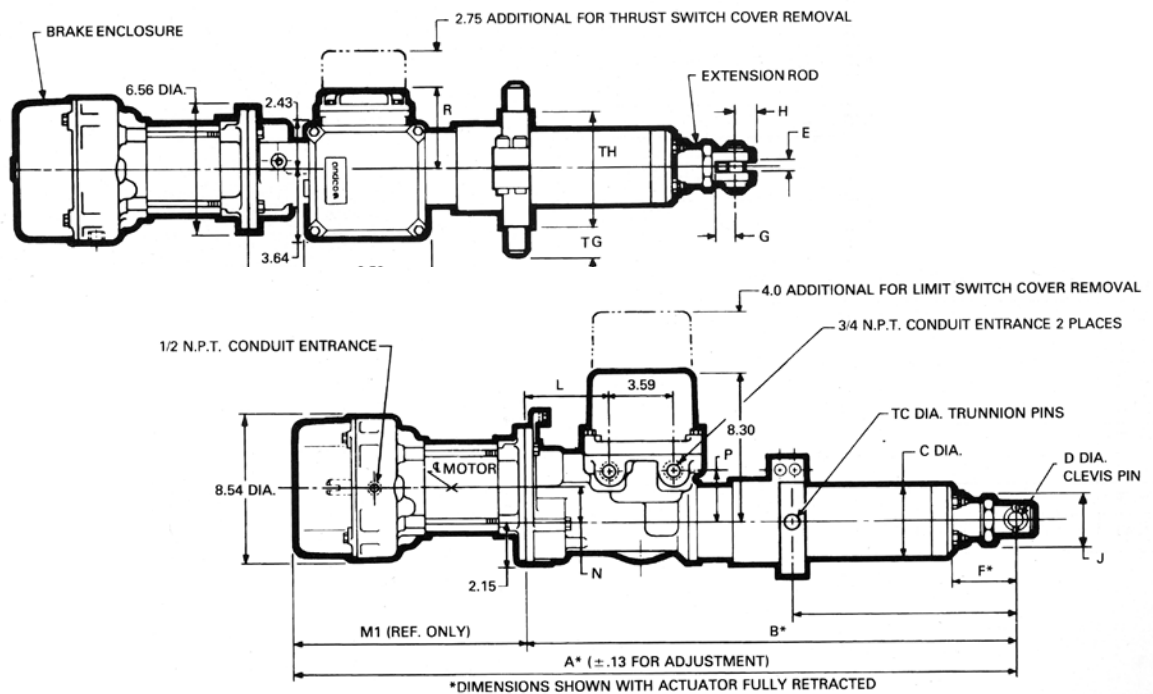

Series	N1	N2	N3
7200	1-1/4" - 20UN	1.12	1.43
7300	1-5/8" - 16 UN	1.18	1.86
7400	1-1/8" - 16UN	2.06	2.35
7500	2-1/2" - 16UN	2.75	3.00

**NOTES**

For trunnion, clevis, and face flange mount dimensions see pages 14 and 15. Dimensions are for reference only. Contact GE for engineering drawings.

# Andco\* 7000 Series\* Actuators

## Trunnion and Clevis Mounting

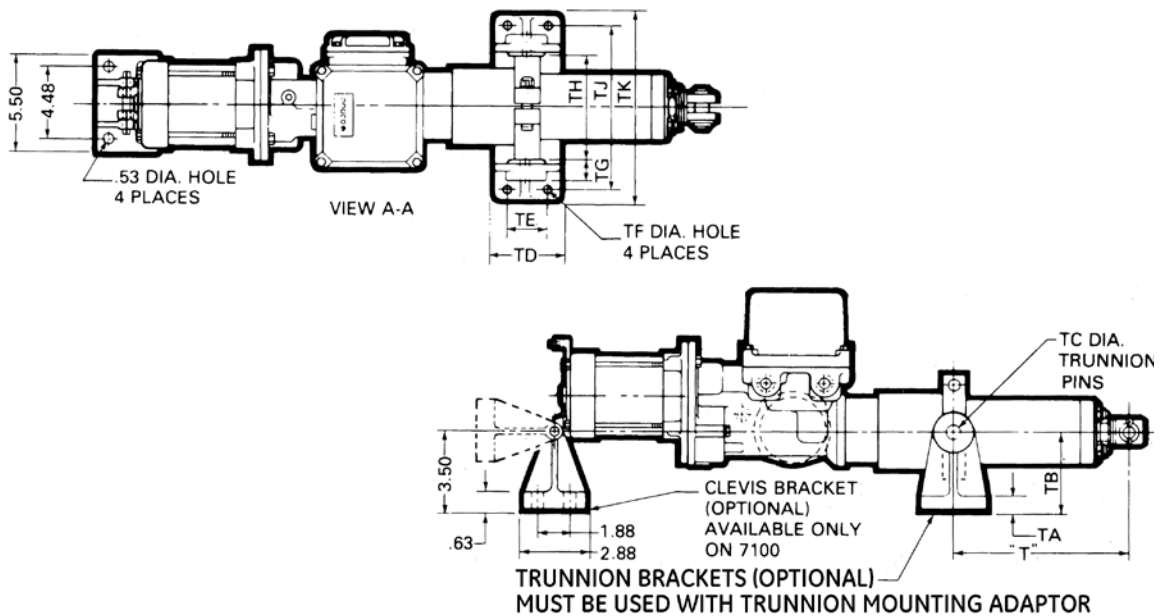

### "T" (Shown with actuator fully retracted)

Series	6" Stroke		12" Stroke		18" Stroke		24" Stroke		30" Stroke		36" Stroke		48" Stroke		60" Stroke	
	MIN	MAX	MIN	MAX	MIN	MAX	MIN	MAX	MIN	MAX	MIN	MAX	MIN	MAX	MIN	MAX
7100-A	6.63	7.63	11.63	13.63	16.63	19.63	19.63	25.63	-	-	-	-	-	-	-	-
7200-A	6.63	7.63	11.63	13.63	16.63	19.63	19.63	25.63	25.63	31.63	31.63	37.63	-	-	-	-
7300-A	10.00	11.50	13.50	17.50	17.00	23.50	21.00	29.50	26.00	35.50	32.00	42.50	38.00	53.50	44.00	65.50
74-7300-A	12.00	14.25	17.00	20.25	20.00	26.25	23.00	32.25	26.00	38.25	32.00	44.25	38.00	56.25	44.00	68.25
7300-B	13.00	14.00	18.00	20.00	21.00	26.00	24.00	32.00	28.00	38.00	32.00	44.00	40.00	56.00	-	-
7400-B	-	-	33.62	33.62	39.62	39.62	45.62	45.62	-	-	57.62	57.62	69.62	69.62	81.62	81.62
7500-B	-	-	36.44	36.44	42.44	42.44	48.44	48.44	-	-	60.44	60.44	77.44	77.44	84.44	84.44

## Trunnion and Clevis Mounting

Series	TA	TB	TC	TD	TE	TF	TG	TH	TJ	TK
7100-A	0.63	3.50	0.50	4.00	1.88	0.53	0.75	4.75	7.47	9.25
7200-A	0.63	3.50	0.50	4.00	1.88	0.53	0.75	4.75	7.47	9.25
7300-A	0.75	4.66	0.87	7.56	5.50	0.66	1.19	6.50	9.50	11.25
74-7300-A	0.75	4.66	1.00	7.56	5.50	0.66	1.43	7.50	10.50	12.25
7300-B	0.75	4.66	0.87	7.56	5.50	0.66	1.19	6.50	9.50	11.25
7400-B	0.75	4.66	1.00	7.56	5.50	0.66	1.50	7.50	10.50	12.25
7500-B	1.50	6.00	1.75	8.50	6.00	1.06	2.50	10.00	14.50	17.00

### NOTES

1. An adjustable trunnion mount is standard on 7200, 7300, and 74-7300 Series actuators (optional on 7100).  
For 7400 Series ball screw actuators with an adjustable trunnion mount use "T" dimension from the 7400 flange mount table.  
Fixed location trunnion pins are standard on 7400 and 7500 Series actuators.
2. Trunnion brackets are optional on all models.
3. Actuators supplied with adjustable trunnion mounting are set at the maximum dimension unless otherwise specified.
4. Dimensions are for reference only. Contact GE for engineering drawings.

# Andco\* 7000 Series\* Actuators

## Face/Flange Mounting

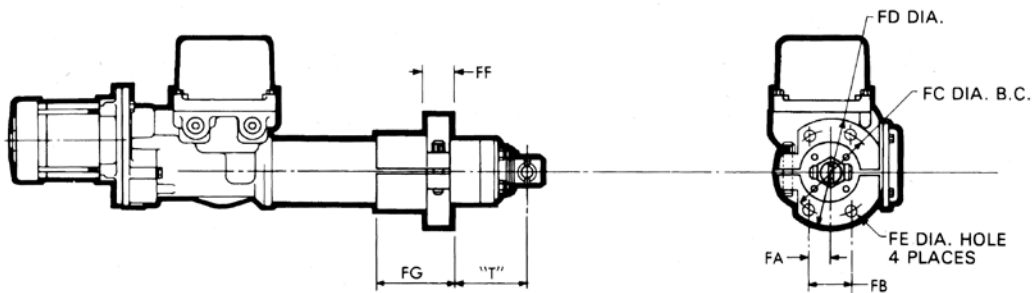

## Face/Flange Mounting

Series	FA	FB	FC	FD	FE	FF	FG
7100-A	1.00	2.00	4.25	5.50	0.56	1.00	4.00
7200-A	1.00	2.00	4.25	5.50	0.56	1.00	4.00
7300-A	1.50	3.00	5.75	7.00	0.69	1.38	4.00
74-7300-A	2.25	4.50	6.50	8.00	0.81	1.00	5.00
7300-B	1.50	3.00	5.75	7.00	0.69	1.38	4.00
7400-B	2.30	4.60	6.50	8.00	0.81	1.00	5.00

## "T" (Shown with Actuator Fully Retracted)

Series	6" Stroke		12" Stroke		18" Stroke		24" Stroke		30" Stroke		36" Stroke		48" Stroke		60" Stroke	
	MIN	MAX	MIN	MAX	MIN	MAX	MIN	MAX	MIN	MAX	MIN	MAX	MIN	MAX	MIN	MAX
7100-A	3.32	6.75	3.32	12.75	6.63	18.75	12.63	24.75	-	-	-	-	-	-	-	-
7200-A	3.32	6.75	3.32	12.75	6.63	18.75	12.63	24.75	18.63	30.75	24.63	36.75	-	-	-	-
7300-A	10.00	11.00	16.00	17.00	22.00	23.00	28.00	29.00	34.00	35.00	40.00	41.00	52.00	53.00	64.00	65.00
74-7300-A	11.00	13.25	17.00	19.25	23.00	25.25	29.00	31.25	35.00	37.25	41.00	43.25	53.00	55.25	65.00	67.25
7300-B	12.00	13.50	18.00	19.50	24.00	25.58	30.00	31.50	36.00	37.58	42.00	43.50	54.00	55.50	-	-
7400-B	-	-	20.00	24.00	25.00	30.00	30.00	36.00	-	-	38.00	43.00	40.00	46.00	43.00	50.00

### NOTES

1. Face/flange actuator may be rotated 90° from arrangement shown.
2. Face/flange location is set at maximum dimension unless otherwise specified.
3. Dimensions are for reference only. Contact GE for engineering drawings.

# Standard Options

## Clevis Mount

A cast iron clevis mount is standard on Eagle and 7100 Series actuators. The optional bracket will allow the actuator to pivot or can be used as a support on rigid mount applications.

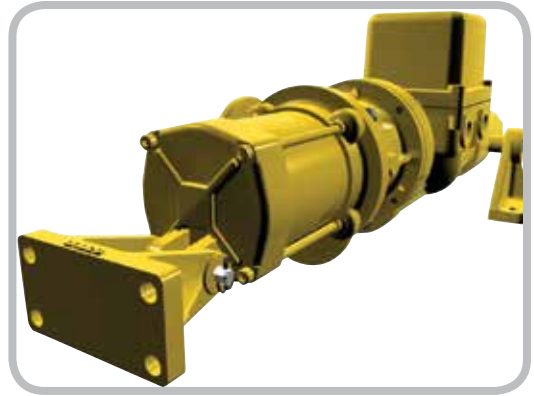

## Adjustable Trunnion Mount and Trunnion Mounting Brackets

Adjustable, high strength, malleable cast iron trunnion mount with alloy steel, heat treated pins, is supplied as standard equipment on all 7200, 7300 and 74-7300 Series actuators. Adjustable trunnion mounting is optional on the Eagle, and 7100 Series actuators. The 7400 and 7500 Series actuators are supplied with alloy steel, heat treated and fixed location trunnion mount. Heavy duty cast and machine trunnion mounting brackets are available as an option on all 7000 Series actuators.

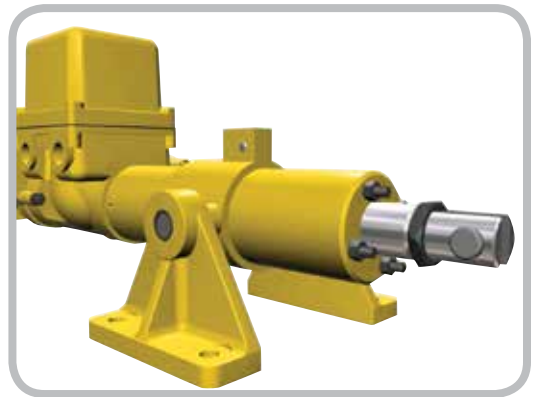

## Adjustable Face/Flange Mount

An adjustable, high strength, malleable iron face/flange mount is available as an option on the Eagle Series, 7100, 7200, 7300, 74-7300, and 7400 Series actuators where rigid mounting is required.

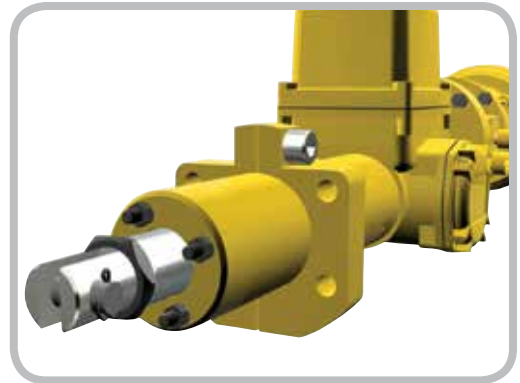

## Manual Override

A handwheel assembly with declutching mechanism is available for manual operation of the 7000, 8000 Series and QR and QRG Series Rotary actuators. Whenever the handwheel is operated, a mechanical override is used to disengage the motor. The actuator can then be positioned manually without risk of injury in the event the motor resumes operation. The actuator will remain in manual operation until the motor is re-energized. A handwheel is not available on ball screw actuators. Manual override without declutching mechanism is available on the Eagle Series.

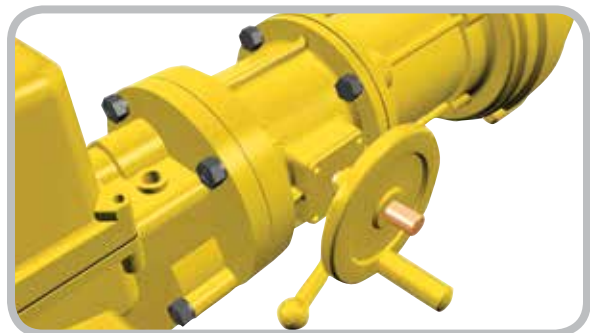

# Standard Options

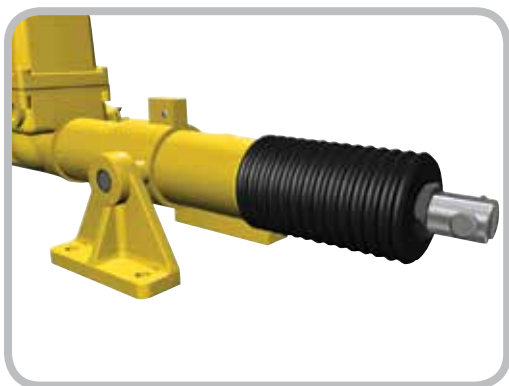

## Extension Rod Cover

The standard plate drive rod resists abrasion and corrosion. Together with the seals in the end cap, the extension rod is a long-life component. For specific applications, such as those requiring protection of the extension rod from dust buildup or chemical splash, rod covers are recommended.



## Adjustable Gear Driven Position Limit Switch

All actuators are supplied with two independently adjustable position limit switches for end-of-travel shutoff as standard.

Two additional switches are available for intermediate positioning on 7000 Series, 8000 Series and Rotary actuators.

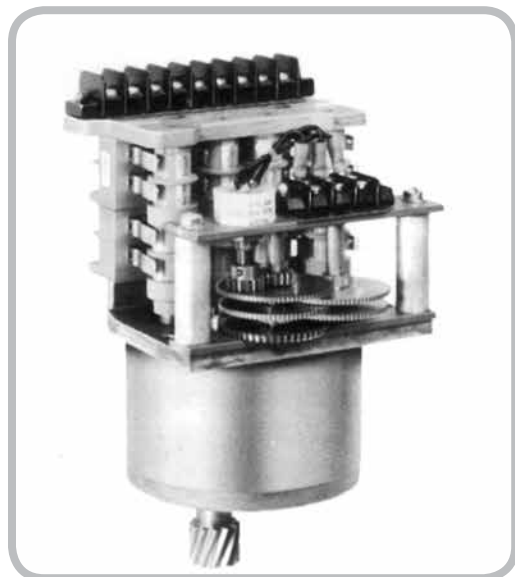

## Gear Driven Potentiometer

A heavy duty gear driven single or dual potentiometers can be supplied as an integral component of the position limit switch.

The potentiometer provides position feedback for remote indication or when a proportional feedback signal is needed for interfacing with automatic control equipment.

An actuator potentiometer is required when using GE controls.



# Standard Options

## Electric Motor Brake

An electric brake option is available for all sizes of Andco 7000, 8000 and QR actuators (standard on all ball screw actuators). The brake is recommended where high vibration is present or for accurate positioning applications when inertial coast is not permitted. The predictable coast of the actuator varies with velocity for each model and with the opposing load the actuator is moving. Consult factory for specific applications.

## Single Phase Electronic (Dynamic) Motor Braking

Automatically applies a D.C. motor voltage to the actuator motor upon shutoff of A.C. power. The brake is prewired and terminated in the actuator. Input voltage is 115 VAC, 60 Hz single phase. Not available on ball screw actuators.

## Three Phase Motor Control

All 7000 Series three phase actuators can be furnished with an integral motor control that includes:

- Reversing contractor
- Thermal overload
- Control transformer with fuse
- Compartment space heater
- Prewired with all connecting points terminated

## Positran™ Transmitter

This position transmitter outputs a 4-20mA signal proportional to actuator position. The signal can be used for the following functions:

- Drive a position indicating meter
- A feedback or control signal for other control devices

A potentiometer and compartment heater are required with the actuator.

Positran is a trademark of Positran Manufacturing, Inc.

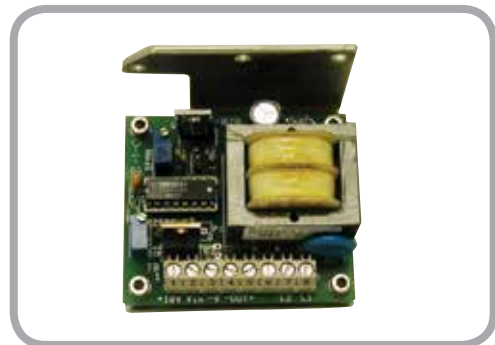
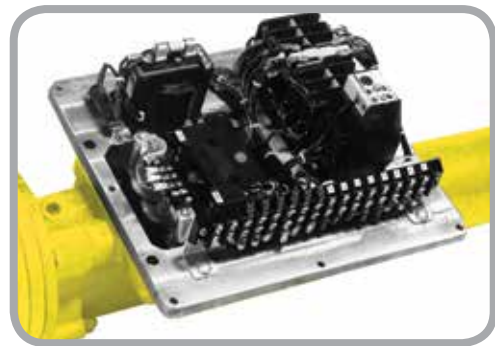

# Electric Actuator Smart Controller (EASC)

## Model SCC10

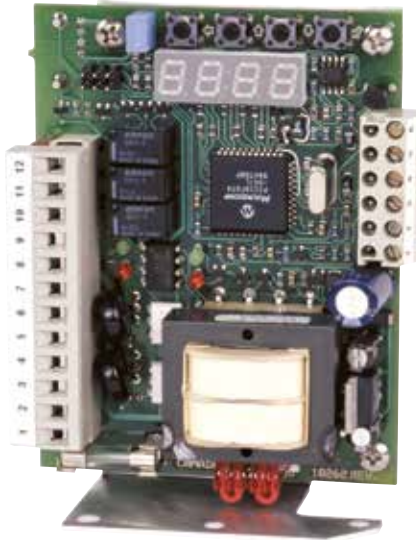

### Models

SCC10-115/230 VAC 115 or 230 Volt A.C. Actuators
SCC10-24 VAC 24 Volt A.C. Actuators

### EASC (Micro-Processor Based Analog Controller)

The Electric Actuator Smart Controller (EASC Model SCC-10) card provides accurate positioning control of electric motor actuators using an analog input signal. Setup and calibration is greatly simplified using microprocessor based technology. There are no dip switches to set or trim pots to adjust. Setup is quick and easy using the EASC menu viewed on an LED display. No external meters are required, even for potentiometer setup. Once the initial menu settings are chosen, the EASC performs a self-calibration routine, applying the menu selections to actual actuator performance. Calibration values are then stored in permanent non-volatile memory.

#### Features

- Onboard LED display facilitates setup and calibration using the EASC Menu Setup.
- Menu selection of input/output ranges including 4-20 mA<sub>dc</sub>, 1-5 VDC, 2-10 VDC and 0-10 VDC, or virtually any custom range required.
- Automatic calibration; no resistors to add; no jumpers, trim pots or dip switches to adjust. Calibration is as simple as pressing a button.
- Three relay outputs: fault, full closed and full open. (A.C. Models Only.)
- Current sensing (over torque protection).
  - Optional on A.C. Models. Standard on D.C. Models.
- Menu selectable fail options.
- Intelligent positioning reduces motor cycling, increases motor life and extends the actuator duty.
- Auto-jog feature. Constantly corrects and refines the positioning accuracy.
- Quick disconnect terminal strips facilitate fast and easy actuator maintenance and troubleshooting.
- Always wires the same; no need to determine rotation direction during installation; rotation is selected using the EASC Menu.
- Robust power switching components, designed specifically for actuator motors, virtually eliminates field failures.

# Electric Actuator Smart Controller (EASC)

## Model SCC10

### Specifications

#### Power Requirements

**Model SCC10-115/230A:** 115 or 230 VAC, 1 Phase, 50/60 Hz. (Jumper selectable)

**Model SCC-24 VAC:** 24 VAC, 50/60 Hz.

**Model SCC-24 VDC:** 10-28 VDC

#### Input Command Signal

Menu selectable factory defaults:

- 4 – 20 mA DC
- 1 – 5 VDC
- 2 – 10 VDC
- 0 – 10 VDC

Infinite adjustment using EASC menu system

#### Signal Impedance

Input: 250 $\Omega$  current, 200K $\Omega$  voltage

Output: maximum load 500 $\Omega$  current, minimum 500K $\Omega$  voltage

#### Dimensions

3-1/2 x 1-5/8 x 4 in.

#### Output Command Signal

Menu selectable factory defaults:

- 4 – 20 mA dc
- 1 – 5 VDC
- 2 – 10 VDC
- 0 – 10 VDC

Infinite adjustment using EASC menu system

#### Power Output

Solid state, isolated from the input command and output position signals and rated at:

- 5 amps continuous at 115 VAC
- 5 amps continuous at 230 VAC
- 5 amps continuous at 24 VAC
- 10 amps continuous at 24 VDC

All ratings assume the EASC is mounted on the actuator base plate.

#### Sensitivity

Fully adjustable from 0.5% of total span, factory set to 1% of total span.

#### Dead Band

Automatically set during calibration. Factory default at 1% of total span. Additional settings available using the EASC Menu System.

#### Zero Adjustment

Automatically set during calibration.

#### Span Adjustment

Automatically set during calibration.

#### Split Range

Settable within the span range using at least 1.5VDC or 3mA of input.

#### Remote Control

Optional Modbus RTU control of all controller functions over a RS-485 multi-drop network

#### Ambient Temperature

-40°F (with heater) to +150°F (-40°C to +65°C)

#### Action on Loss of Command Signal

Factory default:

- Fail in last position (no movement)

Additional settings available through EASC menu:

- Fail open (maximum signal value)
- Fail closed (minimum signal value)
- Fail to a preset position

#### Relay Outputs - A.C. Models Only

Three dry contacts outputs:

- Fault indicating loss of power, fuse failed, command signal loss or failure to move to position in preset time.
- End of travel open
- End of travel closed
- Contact Ratings: 1A @ 30VDC, 0.5A @ 135VAC resistive

# Profibus® DP Controller

## Models DPC-100 and DPC-120

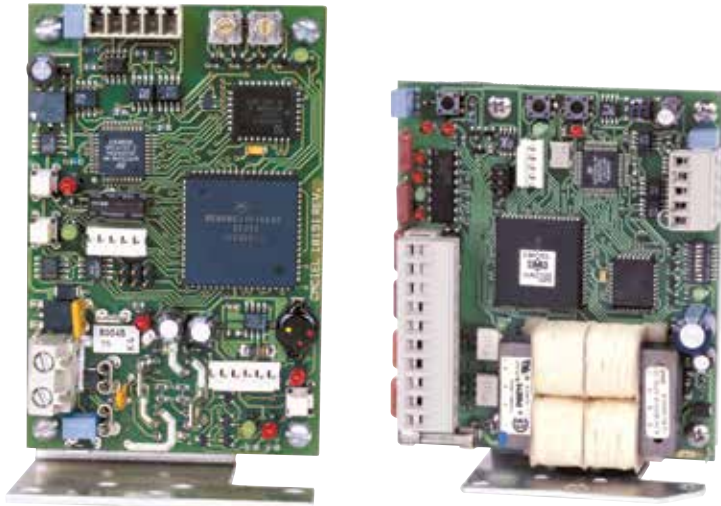

Model
DPC-100 12 or 24 Volt D.C. Actuators

Model
DPC-120 115 Volt A.C. Actuators

### Features

- Two wire control reduces installation and start up time compared to multi-cable wiring
- Automatic calibration cuts down on start up time
- No deadband eliminates need for field adjustment.
- On line configuration of 36 operational parameters using generic Profibus software
- Low power consumption; does not require ventilation
- Electronic overload protection with built-in current monitoring
- LED indicators for input, outputs and communication channel
- Automatic calibration with local pushbutton or remote command
- Dynamic breaking eliminates overshooting
- Robust power switching components, designed specifically for actuator motors, virtually eliminates field failures

### Specifications

#### Power Supply

DPC-100: 24/12 VDC  
DPC-120: 120 VAC

#### Communication Interface

Profibus Standard

#### Protocol

Profibus DP (Distributed Process)

#### Feedback

Potentiometer 1000 Ohms/Optical Encoder

### Application

#### Protocol: Profibus DP (Distributed Process)

For on/off positioning control of motorized valve, it also serves as the vital intelligence link between PLC's in the control room and the actuators in the field. Up to 126 actuated valves can be controlled on a single network. The automatic calibration feature requires no loop tuning. All operating parameters can be set from the communications center over the bus.

#### Position Input Accuracy

1.0% full scale standard, Maximum 0.1%

#### Temperature

-40°F to +158°F (-40°C to +70°C)

#### Relative Humidity

0 to 90% non-condensing

#### Dimensions

DPC-100: 4.0 x 1.5 x 2.5 in.  
DPC-120: 4.25 x 1.75 x 3.75 in.

#### The DPC-100 & DPC-120 provide the following status and fault signals:

- Valve full closed
- Valve full open
- Percentage of open
- Valve seeking position
- Motor running
- Valve closing
- Valve opening
- Motor thermostat tripped
- Incomplete travel
- Valve opening or closing manually
- Valve jammed/current limiting
- Motor still energized after stop or end of travel
- Controller self-test (detects problems)
- Communication failure
- Average running current load
- Peak running current load
- Idle current load

# DeviceNet™

## Model DNET 115



<b>Model</b>
DNET115 115 Volt A.C. Actuators

### Application

For on/off or positioning control of motorized valves. DeviceNet™ is a type of communication network that allows up to 63 field devices to be linked together with a single five-conductor cable. DeviceNet is a product of Allen-Bradley and is an open, non-proprietary, bus network. Typically, a DeviceNet system is used with the Allen-Bradley™ PLC5 and SLC series of programmable logic controllers. A standard DeviceNet Scanner interface is available for both types. Devices in the field are connected via a drop line to a 5 conductor trunk-line that is then routed to the scanner card.

### Features

- Provides open/stop/close or positioning control with limit switch status feedback
- Provides instantaneous motor reversal protection
- Command and end-of-travel verification alarm
- Conforms to ODVA standards
- Easy-to-see LED indicators for all control outputs, status inputs and diagnostic alarm
- ESD functions for 'go open', 'stay put', or 'go closed'

### Specifications

#### Hardware Specifications

**Supply Power:** 2W @ 24VDC

**Operating Temperature:** -4°F - 158°F  
(-20°C - 70°C)

**Storage Temperature:** -40°F - 176°F  
(-40°C - 80°C)

**Humidity:** 90% Non Condensing

**Solid State Outputs:** (2) Isolated  
600VAC 15A

**Digital Inputs:** (8) Dry Contacts

**Analog Inputs:** (2) Channels (see below)

**Processor:** Temic 89C51CC01

**RAM:** 1K

**Flash:** 32K

**EEPROM:** 32K

#### Serious Interfaces

One CAN 2.0 port.

#### Network Communication Protocols

Module Supports DeviceNet™ Group 2 Slave.

#### Analog Inputs Specification

**Resolution:** 10bit

**Accuracy:** 1% of FS.

**Linearity:** 1% of FS.

**Temperature Drift:** 2% of FS.

**Range:** 0 to 5V or 0-20mA input for AI1  
1-5K Potentiometer for the  
Position Feedback.

#### Technical Summary of DeviceNet™

**Network Size:** Up to 64 nodes  
(including scanner)

**Network Length:** Up to 1,640 ft. at 125 Kbps.

**Data Packets:** 0-8 bytes

**Bus Topology:** Trunkline/Dropline

**Cable:** 5-Conductor cable (2 for power,  
2 for communication, and 1  
for ground).

**Thick Trunk Lines:** Belden 3082A or 3083A

**Thin Drop Lines:** Belden 3084A or 3085A

**Drop Lines:** Max. drop length is 20 ft. with  
cumulative drop length of 512 ft.

**Repeaters:** Not currently, but expected in  
future revisions of specifications.

#### Input/Output Listing

##### Digital Input Status:

- Bit 0 Communication Loss
- Bit 1 Reserved
- Bit 2 Loss of Position Signal
- Bit 3 Motor Stall
- Bit 4 Limit Calibration Incorrect
- Bit 5 Thermostat Trip
- Bit 6 Manual Operation
- Bit 7-15 Reserved

#### Digital Output Command:

- Bit 0 Open Command
- Bit 1 Close Command
- Bit 2 Stop Command
- Bit 3 ESD Command
- Bit 4-7 Future

#### Environmental

##### Temperature Range:

Storage: -40°F - 194°F

(-40°C to +90°C)

Operating: -4°F - 176°F

(-20°C to +80°C)

##### Humidity Range:

5% to 95% at 77° F (25°C)  
non-condensing

##### Vibration:

IEC 6B-2-6 1G @ 40-50 Hz.,  
0.012p-p @ 10-40 Hz.

# Modbus®

## Model SCC05



### Application

The Modbus is an application specific controller, designed for positioning electric actuators using rotary feedback. Typical devices include rotary and linear actuators. Feedback may be via a potentiometer or a quadrature optical encoder. Controller outputs can drive small electric motors or motor starters directly.

A Modbus-485 communication network allows up to 100 devices on a single channel. The Modbus is powered by 24VDC and provides four supervisory inputs, configurable as limit switches or force open/close signals.

Automatic calibration is provided which requires no loop tuning. All operating parameters can be set as registers in the Modbus communications map.

### Features

- High resolution position input for up to 0.1% accuracy
- 4-120/240VAC inputs for open and closed limit switches and 2 general purpose inputs
- Simple 4-wire Modbus-485 communication network includes supervisory power
- Robust communication, up to 500m cable length
- Pluggable terminal strips for easy field installation
- Direct mounting within the actuator
- Low power consumption; does not require ventilation
- Electronic overload protection with built-in current monitoring optional
- High power outputs can directly drive small motors
- LED indicators on inputs, outputs and communication channel
- Automatic calibration using local push button or remote command
- Multi-vendor PLC support through the standard Modbus communication module

### Typical Applications

- Blending of bulk materials
- Petroleum products and other liquids flow control
- Level control for maintaining process supply

### Specifications

#### Actuator

Voltage	120/240VAC 1Ø
Current	4A (2 minute 25% duty-cycle)
Fuse	GMA 4 replaceable

#### Supervisory

Voltage	10 to 25VDC
Current	30mA @ 24VDC

#### Auxiliary Inputs

Voltage	120/240VAC
Current	min 10mA / max 20mA

#### Communication

Standard	Modbus-RS485 differential
Distance	500m (1,640ft.)
Input Load	12K ohm, standard
Termination	120Ω balanced line

#### Position

Resolution	12 bit (1 part in 4096)
Accuracy	0.1% full scale
Potentiometer	1000Ω typical (500 to 10kΩ)
Quadrature	1000 to 4096 pulses
Optical Encoder	

#### Environment

Temperature	-40°F to +158°F (-40°C to +70°C)
Relative Humidity	0 to 95% non-condensing

#### Dimensions

Length	96mm (3.75 in)
Width	70mm (2.75 in)
Height	36mm (1.40 in)



**GE Oil & Gas**

16240 Port Northwest Drive

Houston, Texas 77041-2645 USA

T: +1 832.590.2306

U.S. Toll Free T: 800.945.9898

F: +1 713.849.2879

Email: [andcoactuators.inquiries@ge.com](mailto:andcoactuators.inquiries@ge.com)

Visit us online at: [www.ge.com/energy](http://www.ge.com/energy)

©2016, General Electric Company

All Rights Reserved

\* Trademark of General Electric Company

